

# Stahl- & Edelstahl-Schneidringverschraubungen ISO 8434-1

1



## Gerade Einschraubverschraubungen mit Elastomerdichtung G-Gewinde

Typ	Typ	Typ Klemmring	Rohr Ø	Einschraub- gewinde
Stahl verzinkt	1.4571	1.4571 (NC)	außen	
<b>leichte Baureihe</b>				
GE 6 LR ED	GE 6 LR ES ED	GE 6 LR NC ED	6 L	G 1/8"
GE 6 LR 1/4 ED	GE 6 LR 1/4 ES ED	GE 6 LR 1/4 NC ED	6 L	G 1/4"
GE 6 LR 3/8 ED	GE 6 LR 3/8 ES ED	GE 6 LR 3/8 NC ED	6 L	G 3/8"
---	GE 6 LR 1/2 ES ED	GE 6 LR 1/2 NC ED	6 L	G 1/2"
GE 8 LR ED	GE 8 LR ES ED	GE 8 LR NC ED	8 L	G 1/4"
GE 8 LR 1/8 ED	GE 8 LR 1/8 ES ED	GE 8 LR 1/8 NC ED	8 L	G 1/8"
GE 8 LR 3/8 ED	GE 8 LR 3/8 ES ED	GE 8 LR 3/8 NC ED	8 L	G 3/8"
GE 8 LR 1/2 ED	GE 8 LR 1/2 ES ED	GE 8 LR 1/2 NC ED	8 L	G 1/2"
GE 10 LR ED	GE 10 LR ES ED	GE 10 LR NC ED	10 L	G 1/4"
GE 10 LR 1/8 ED	GE 10 LR 1/8 ES ED	GE 10 LR 1/8 NC ED	10 L	G 1/8"
GE 10 LR 3/8 ED	GE 10 LR 3/8 ES ED	GE 10 LR 3/8 NC ED	10 L	G 3/8"
GE 10 LR 1/2 ED	GE 10 LR 1/2 ES ED	GE 10 LR 1/2 NC ED	10 L	G 1/2"
GE 12 LR ED	GE 12 LR ES ED	GE 12 LR NC ED	12 L	G 3/8"
---	GE 12 LR 1/8 ES ED	GE 12 LR 1/8 NC ED	12 L	G 1/8"
GE 12 LR 1/4 ED	GE 12 LR 1/4 ES ED	GE 12 LR 1/4 NC ED	12 L	G 1/4"
GE 12 LR 1/2 ED	GE 12 LR 1/2 ES ED	GE 12 LR 1/2 NC ED	12 L	G 1/2"
---	GE 12 LR 3/4 ES ED	GE 12 LR 3/4 NC ED	12 L	G 3/4"
GE 15 LR ED	GE 15 LR ES ED	GE 15 LR NC ED	15 L	G 1/2"
---	GE 15 LR 1/4 ES ED	GE 15 LR 1/4 NC ED	15 L	G 1/4"
GE 15 LR 3/8 ED	GE 15 LR 3/8 ES ED	GE 15 LR 3/8 NC ED	15 L	G 3/8"
GE 15 LR 1/2 ED	GE 15 LR 1/2 ES ED	GE 15 LR 1/2 NC ED	15 L	G 1/2"
GE 18 LR ED	GE 18 LR ES ED	GE 18 LR NC ED	18 L	G 1/2"
---	GE 18 LR 3/8 ES ED	GE 18 LR 3/8 NC ED	18 L	G 3/8"
GE 18 LR 3/4 ED	GE 18 LR 3/4 ES ED	GE 18 LR 3/4 NC ED	18 L	G 3/4"
---	GE 22 LR 3/8 ES ED	GE 22 LR 3/8 NC ED	22 L	G 3/8"
GE 22 LR 1/2 ED	GE 22 LR 1/2 ES ED	GE 22 LR 1/2 NC ED	22 L	G 1/2"
GE 22 LR 1 ED	GE 22 LR 1 ES ED	GE 22 LR 1 NC ED	22 L	G 1"
GE 28 LR ED	GE 28 LR ES ED	---	28 L	G 1"
---	GE 28 LR 1/2 ES ED	---	28 L	G 1/2"
GE 28 LR 3/4 ED	GE 28 LR 3/4 ES ED	---	28 L	G 3/4"
---	GE 28 LR 1 1/4 ES ED	---	28 L	G 1 1/4"
GE 35 LR ED	GE 35 LR ES ED	---	35 L	G 1 1/4"
---	GE 35 LR 1/2 ES ED	---	35 L	G 1/2"
---	GE 35 LR 3/4 ES ED	---	35 L	G 3/4"
GE 35 LR 1 ED	GE 35 LR 1 ES ED	---	35 L	G 1"
---	GE 35 LR 1 1/2 ES ED	---	35 L	G 1 1/2"
GE 42 LR ED	GE 42 LR ES ED	---	42 L	G 1 1/2"
---	GE 42 LR 1 ES ED	---	42 L	G 1"
GE 42 LR 1 1/4 ED	GE 42 LR 1 1/4 ES ED	---	42 L	G 1 1/4"
<b>schwere Baureihe</b>				
GE 6 SR ED	GE 6 SR ES ED	---	6 S	G 1/4"
---	GE 6 SR 1/8 ES ED	---	6 S	G 1/8"
---	GE 6 SR 3/8 ES ED	---	6 S	G 3/8"
---	GE 6 SR 1/2 ES ED	---	6 S	G 1/2"
---	GE 6 SR 3/4 ES ED	---	6 S	G 3/4"
GE 8 SR ED	GE 8 SR ES ED	---	8 S	G 1/4"
GE 8 SR 3/8 ED	GE 8 SR 3/8 ES ED	---	8 S	G 3/8"
---	GE 8 SR 1/2 ES ED	---	8 S	G 1/2"
GE 10 SR ED	GE 10 SR ES ED	---	10 S	G 3/8"
GE 10 SR 1/4 ED	GE 10 SR 1/4 ES ED	---	10 S	G 1/4"
GE 10 SR 1/2 ED	GE 10 SR 1/2 ES ED	---	10 S	G 1/2"
GE 12 SR ED	GE 12 SR ES ED	---	12 S	G 3/8"
GE 12 SR 1/4 ED	GE 12 SR 1/4 ES ED	---	12 S	G 1/4"
GE 12 SR 1/2 ED	GE 12 SR 1/2 ES ED	---	12 S	G 1/2"
---	GE 12 SR 3/4 ES ED	---	12 S	G 3/4"
GE 14 SR ED	GE 14 SR ES ED	---	14 S	G 1/2"
---	GE 14 SR 1/4 ES ED	---	14 S	G 1/4"
GE 14 SR 3/8 ED	GE 14 SR 3/8 ES ED	---	14 S	G 3/8"
---	GE 14 SR 3/4 ES ED	---	14 S	G 3/4"
GE 16 SR ED	GE 16 SR ES ED	---	16 S	G 1/2"
GE 16 SR 3/8 ED	GE 16 SR 3/8 ES ED	---	16 S	G 3/8"
GE 16 SR 3/4 ED	GE 16 SR 3/4 ES ED	---	16 S	G 3/4"

Weitere Größen auf der nächsten Seite

weitere Größen siehe nächste Seite

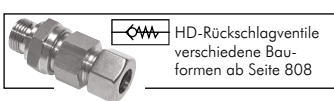

Alle Angaben verstehen sich als unverbindliche Richtwerte! Für nicht schriftlich bestätigte Datenauswahl übernehmen wir keine Haftung. Druckangaben beziehen sich, soweit nicht an

# Stahl- & Edelstahl-Schneidringverschraubungen ISO 8434-1

Gerade Einschraubverschraubungen mit Elastomerdichtung				G-Gewinde	
Typ	Typ	Typ Klemmring	Rohr Ø	Einschraub- gewinde	
Stahl verzinkt	1.4571	1.4571 (NC)	außen		
schwere Baureihe					
GE 20 SR ED	GE 20 SR ES ED	---	20 S	G 3/4"	
GE 20 SR 1/2 ED	GE 20 SR 1/2 ES ED	---	20 S	G 1/2"	
GE 20 SR 1 ED	GE 20 SR 1 ES ED	---	20 S	G 1"	
---	GE 20 SR 1 1/4 ES ED	---	20 S	G 1 1/4"	
---	GE 20 SR 1 1/2 ES ED	---	20 S	G 1 1/2"	
GE 25 SR ED	GE 25 SR ES ED	---	25 S	G 1"	
---	GE 25 SR 1/2 ES ED	---	25 S	G 1/2"	
GE 25 SR 3/4 ED	GE 25 SR 3/4 ES ED	---	25 S	G 3/4"	
---	GE 25 SR 1 1/4 ES ED	---	25 S	G 1 1/4"	
---	GE 25 SR 1 1/2 ES ED	---	25 S	G 1 1/2"	
GE 30 SR ED	GE 30 SR ES ED	---	30 S	G 1 1/4"	
GE 30 SR 1 ED	GE 30 SR 1 ES ED	---	30 S	G 1"	
---	GE 30 SR 1 1/2 ES ED	---	30 S	G 1 1/2"	
GE 38 SR ED	GE 38 SR ES ED	---	38 S	G 1 1/2"	
GE 38 SR 1 1/4 ED	GE 38 SR 1 1/4 ES ED	---	38 S	G 1 1/4"	

Fortsetzung  
von Vorseite

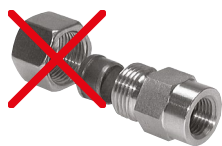

**!** Wünschen Sie eine Verschraubung ohne Mutter und Schneidring, dann setzen Sie bitte ein „X“ vor die Artikelnummer.

Profildichtringe für Schneidringverschraubungen			G-Gewinde			
Typ NBR (-35°C bis max. +100°C)	Typ FKM (-15°C bis max. +200°C)	für	Gewinde	d	D	s
DR 18 ED NBR	DR 18 ED V		G 1/8"	8,4	11,9	1,0
DR 14 ED NBR	DR 14 ED V		G 1/4"	11,6	16,5	1,5
DR 38 ED NBR	DR 38 ED V		G 3/8"	14,7	18,9	1,5
DR 12 ED NBR	DR 12 ED V		G 1/2"	18,5	23,9	1,5
DR 34 ED NBR	DR 34 ED V		G 3/4"	23,9	29,2	1,5
DR 10 ED NBR	DR 10 ED V		G 1"	29,7	35,7	2,0
DR 114 ED NBR	DR 114 ED V		G 1 1/4"	38,8	45,8	2,0
DR 112 ED NBR	DR 112 ED V		G 1 1/2"	44,7	50,7	2,0

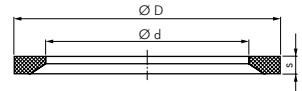

## Anschlüsse mit G-Gewinde / R-Gewinde

Nennmaß	Gangzahl auf 1 Zoll	D	d
G/R 1/8"	28	9,7	8,6
G/R 1/4"	19	13,2	11,5
G/R 3/8"	19	16,7	15,0
G/R 1/2"	14	21,0	18,6
G/R 5/8"	14	22,9	20,6
G/R 3/4"	14	26,4	24,1
G/R 1"	11	33,3	30,3
G/R 1 1/4"	11	41,9	39,0
G/R 1 1/2"	11	47,8	44,9
G/R 2"	11	59,6	56,7
G/R 2 1/2"	11	75,2	72,2
G/R 3"	11	87,9	84,9
G/R 4"	11	113,0	110,1
G/R 5"	11	138,4	135,4
G/R 6"	11	163,8	160,9

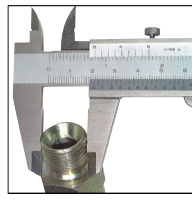
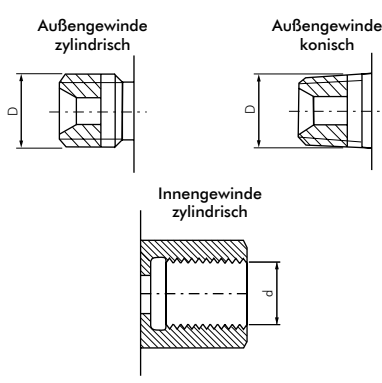

**F** Weitere Gewindetabellen finden Sie auf Seite 1179.

Alle Angaben verstehen sich als unverbindliche Richtwerte! Für nicht schriftlich bestätigte Datenauswahl übernehmen wir keine Haftung. Druckangaben beziehen sich, soweit nicht anders angegeben, auf Flüssigkeiten der Gruppe II bei +20°C.