

Gewindestifte mit Innensechskant & Ringschneide

DIN 916 / ISO 4029

Typ Stahl 45 H	Typ Edelstahl A2	D	L	S	Typ Stahl 45 H	Typ Edelstahl A2	D	L	S
916-M3x5	916-M3x5 ES	M 3	5	1,5	916-M6x16	916-M6x16 ES	M 6	16	3
916-M3x6	916-M3x6 ES	M 3	6	1,5	916-M6x20	916-M6x20 ES	M 6	20	3
916-M3x8	916-M3x8 ES	M 3	8	1,5	916-M6x25	916-M6x25 ES	M 6	25	3
916-M3x10	916-M3x10 ES	M 3	10	1,5	916-M6x30	916-M6x30 ES	M 6	30	3
916-M4x5	916-M4x5 ES	M 4	5	2	916-M6x35	916-M6x35 ES	M 6	35	3
916-M4x6	916-M4x6 ES	M 4	6	2	916-M8x8	916-M8x8 ES	M 8	8	4
916-M4x8	916-M4x8 ES	M 4	8	2	916-M8x10	916-M8x10 ES	M 8	10	4
916-M4x10	916-M4x10 ES	M 4	10	2	916-M8x12	916-M8x12 ES	M 8	12	4
916-M4x12	916-M4x12 ES	M 4	12	2	916-M8x16	916-M8x16 ES	M 8	16	4
916-M5x5	916-M5x5 ES	M 5	5	2,5	916-M8x20	916-M8x20 ES	M 8	20	4
916-M5x6	916-M5x6 ES	M 5	6	2,5	916-M8x25	916-M8x25 ES	M 8	25	4
916-M5x8	916-M5x8 ES	M 5	8	2,5	916-M8x30	916-M8x30 ES	M 8	30	4
916-M5x10	916-M5x10 ES	M 5	10	2,5	916-M8x35	916-M8x35 ES	M 8	35	4
916-M5x12	916-M5x12 ES	M 5	12	2,5	916-M8x40	---	M 8	40	4
916-M5x16	916-M5x16 ES	M 5	16	2,5	916-M8x50	---	M 8	50	4
916-M5x20	916-M5x20 ES	M 5	20	2,5	916-M10x10	916-M10x10 ES	M 10	10	5
916-M5x25	---	M 5	25	2,5	916-M10x12	916-M10x12 ES	M 10	12	5
916-M5x30	---	M 5	30	2,5	916-M10x16	916-M10x16 ES	M 10	16	5
916-M6x8	916-M6x8 ES	M 6	8	3	916-M10x20	916-M10x20 ES	M 10	20	5
916-M6x10	916-M6x10 ES	M 6	10	3	916-M10x25	916-M10x25 ES	M 10	25	5

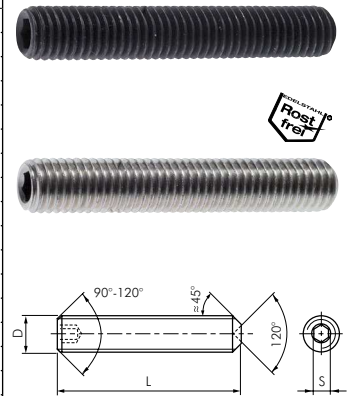

Gewindestangen

DIN 975 / DIN 976

Stangenlänge: 1 mtr.

Optional: Linksgewinde -LH **NEU**, Stahl 8.8 blank (schwarz) -ST **NEU**

Typ Stahl verzinkt 4.6	Typ Stahl verzinkt 8.8	Typ Edelstahl A2	D
975-M3	---	975-M3 ES	M 3
975-M4	975-M4 8.8	975-M4 ES	M 4
975-M5	975-M5 8.8	975-M5 ES	M 5
975-M6	975-M6 8.8	975-M6 ES	M 6
975-M8	975-M8 8.8	975-M8 ES	M 8
975-M10	975-M10 8.8	975-M10 ES	M 10
975-M12	975-M12 8.8	975-M12 ES	M 12
975-M14	975-M14 8.8	975-M14 ES	M 14
975-M16	975-M16 8.8	975-M16 ES	M 16
975-M18	975-M18 8.8	975-M18 ES NEU	M 18
975-M20	975-M20 8.8	975-M20 ES NEU	M 20
975-M22	975-M22 8.8	975-M22 ES	M 22
975-M24	975-M24 8.8	975-M24 ES	M 24
975-M27	975-M27 8.8	975-M27 ES	M 27
975-M30	975-M30 8.8	975-M30 ES	M 30
975-M33	---	---	M 33
975-M36	---	---	M 36

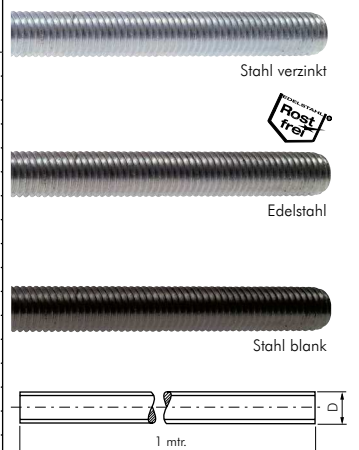

Bestellbeispiel: 975-M3 **

Standardtyp

Kennzeichen der Optionen

Linksgewinde -LH **NEU**

Stahl 8.8 blank (schwarz) . . -ST **NEU**

Verbindungsuffen für Gewindestangen

Typ Stahl verzinkt	Typ Edelstahl A2	D	L	S
GWS 5 VM	---	M 5	20	8
GWS 6 VM	GWS 6 VM ES	M 6	30	10
GWS 8 VM	GWS 8 VM ES	M 8	30	13
GWS 10 VM	GWS 10 VM ES	M 10	30	17
GWS 12 VM	GWS 12 VM ES	M 12	40	19
GWS 16 VM	GWS 16 VM ES	M 16	50	24
GWS 20 VM	GWS 20 VM ES	M 20	50	30
GWS 24 VM NEU	GWS 24 VM ES NEU	M 24	72	36
GWS 30 VM NEU	GWS 30 VM ES NEU	M 30	90	46

